



World Class Standards

Experiences from the 1st ETSI TTCN-3 Tool Plugtest

T3UC, Sophia-Antipolis, Jun 5 2009

Stephan Schulz
Technical Coordinator
© ETSI 2009. All rights reserved

Outline

- History
- About the test specification
- Testing Results
- Conclusions

History

- ❑ In Oct 2008 ETSI MTS (Chairman Dieter Hogrefe) had the idea to organize a TTCN-3 tool Plugtest
 - Basis is ETSI TR 102 976 “Mobile reference tests for TTCN-3 tools”
 - Supported by 4 tool makers

- ❑ In Nov in a LTE test specification conference call 7(!) tool makers indicated interest in participating in this Plugtest

- ❑ Prior to the Plugtest 4 tool makers claimed successful compilation and execution using intra approach

- ❑ Elvior (MessageMagic) and Testing Technologies (TTworkbench) participated in the Plugtest at ETSI June 2 & 3 2009

About the Test Specification

- ❑ **Complex TTCN-3 test suite with a reference and a mirror part**
 - Reference part is based on a snapshot of 3GPP LTE benchmark tests
 - Mirror part simulates conformant LTE terminal behaviour
- ❑ **Challenges in test suite**
 - Use of ASN.1
 - Large files (22,000 LoC per module)
 - Complex templates
 - Strict timers and message bursts
- ❑ **Main issues in Plugtests preparation phase**
 - Correct settings of module parameters
 - Missing use of valueof operation
 - Encoding (PER & TLI XML) and adaptation (UDP) for inter approach
 - Mix of standard versions (non TTCN-3 2008 features)
 - Consistent ASN.1 DEFAULT handling

Results

- ❑ **Compilation**
 - **100% pass !**
- ❑ **Intra testing (execution within the same tool)**
 - **100% pass !**
- ❑ **Inter testing (reference executed by one and mirror by other tool)**
 - **100% pass !**
- ❑ **Some more statistics**
 - **4 test sessions (2 intra + 2 inter)**
 - **34 tests executed**
 - **70 mega bytes of test execution log files generated**
- ❑ **All results were agreed by all participants and validated by ETSI**

Example: Intra test configuration

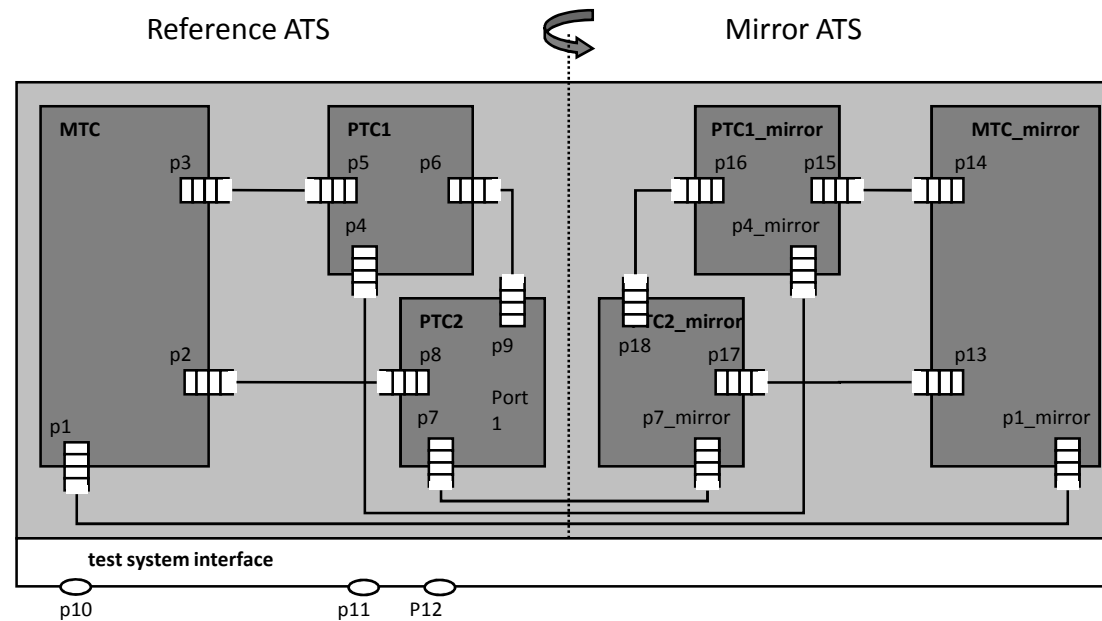

Conclusions

- ❑ The organization of this Plugtest has brought tool makers closer together
- ❑ No grey areas identified in TTCN-3 standards based on the compilation and execution of this LTE benchmark test suite
- ❑ Participants proved that commercial TTCN-3 tools are able to compile and execute the same complex TTCN-3 test suite
 - Elvior
 - Testing Technologies
 - MessageMagic
- ❑ Plugtest results to be placed on www.ttcn-3.org
- ❑ A second MTS Plugtest?
 - TTCN-3:2009 ?





Thank you!